



I-SHEET NUMBER: INST-00140
 PART NUMBER: EXJ19T-TX
 PRODUCT: EYPX HOOP STEP
 APPLICATION: 19-20 JEEP JT 4D



PARTS INCLUDED	QTY
Step Rail	2
Rocker Panel mounting Brackets	6

DO NOT USE IMPACT TOOLS

Step 1: Locate the driver side step rail.

HARDWARE DESCRIPTION	QTY.
KIT# HWK-00034X	
M8x30mm flanged hex bolt with washer	6
M8x25mm Flanged hex head bolt (Black zinc)	12
M8 flanged nuts	12
3/8" x 3/4" carriage bolts	12
3/8" Flanged nuts	12

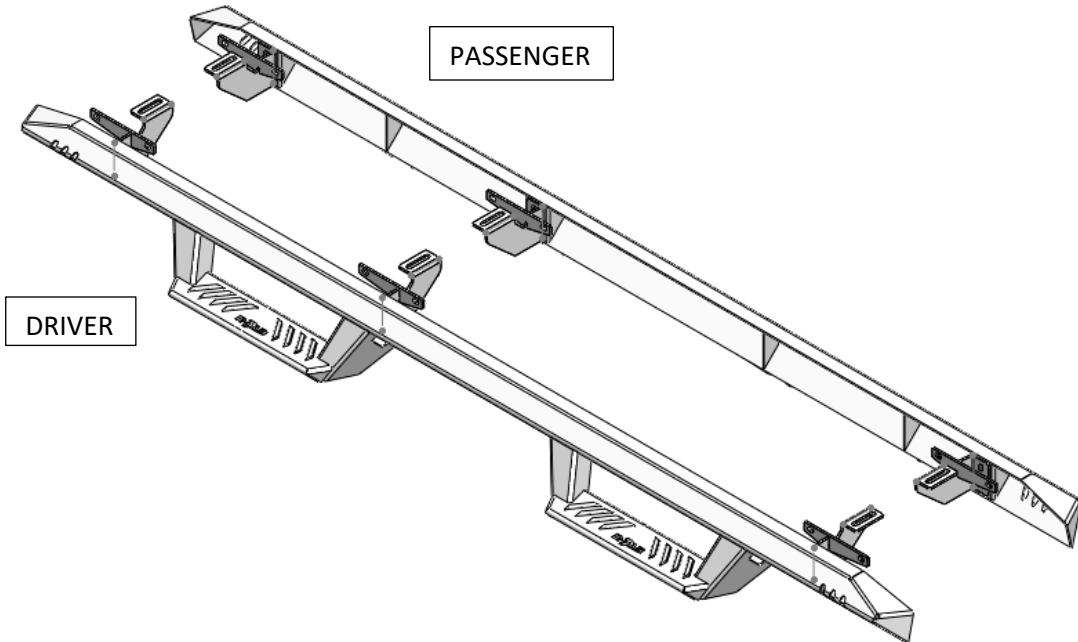

Step 2: Install three rocker panel brackets to the attachments points located on the backside of the channel using the supplied 3/8" x 3/4" carriage bolts and 3/8" flanged nuts. Leave finger tight for now.

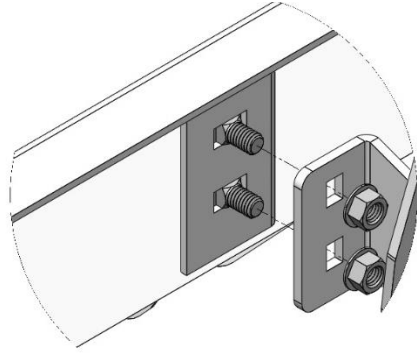

Step 3: Remove the factory running boards and discard.



Step 4: Carefully raise step assembly into position and align the brackets with the factory mounting points with the horizontal part of the bracket on the outside of the pinch weld.

Step 5: Next, start one of the supplied M8x30mm hex head flanged bolt and washer through the center bracket into the factory-threaded hole and leave loose.

Step 6: Start two M8x25mm black zinc flanged bolts and two M8 flanged nuts in the pinch weld and leave loose for final adjustment.



Step 7: Continue installing the rest of the hardware in the remaining brackets and leave loose.

Step 8: Next, adjust the step assembly up/down and front/back to level out the step rail with body panel and then tighten step to brackets at 20 ft. /lbs.

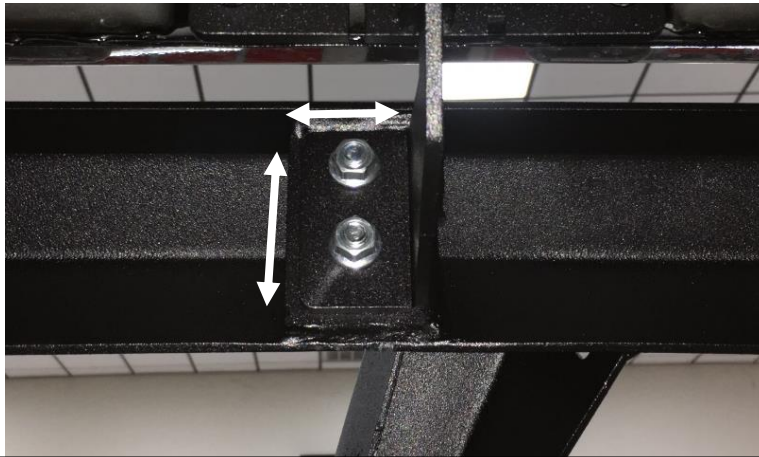

**** ALL HARDWARE MUST BE LOOSE FOR FINIAL ADJUSTMENT. ****

Step. 9: After final positioning, completely tighten all (x6) M8x25mm flanged hex bolts in the pinch weld attachment.

Step. 10: Next, tighten all (x3) upper body mount positions to 17-20 Ft/lbs. torque.

Step. 11: Repeat steps 2-10 for passenger side.