



**ADVENTURE  
FURTHER®**

**50" XROSS BAR™ 6-LIGHT  
SLIMLITE® LED OVERHEAD SYSTEM  
FOR #97060/#97062**

## 50" XROSS BAR OVERHEAD 6-LIGHT SLIMLITE LED SYSTEM

The KC Xross Bar™ will take the place of any 50" light bar. It is made from 6063-T6 extruded aluminum. The KC Xross Bar has the ability to fit a variety of different brackets. The KC Xross Bar measures 51.375" in length, allowing it to fit where most standard 50" LED light bars are generally used for overhead vehicle applications.

**WARNING:** Please read all instructions before beginning installation. These guidelines are provided in good faith to help prevent any issues arising from errors during installation. The manufacturer of this product shall not be held responsible for any user actions taken or not taken during installation. There are many details of the installation that are assumed to be general mechanical knowledge to experienced installers; which are not detailed in these instructions. These installation guidelines are intended to serve as professional recommendations and are not as a step-by-step, fail-safe installation checklist. Selection of an experienced installer is the sole responsibility of the project owner.



### Parts Included:

(1) KC 7418 - Xross Bar Light Mount

(3) KC #100 - SlimLite LED Pair Packs which include (3) Wire Harnesses or any (3) KC LED Pair Packs

### TOOLS NEEDED FOR INSTALLATION

During this installation you will need a 13mm wrench or socket and also a #2 phillips head screwdriver.

**13mm Wrench**



**#2 Philips Screwdriver**



**Wire Cutter/ Stripper/ Crimper**

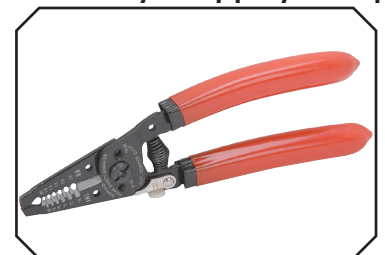

\*Optional

# XROSS BAR 6-LIGHT SLIMLITE LED OVERHEAD SYSTEM INSTALLATION

## INSTALLATION INSTRUCTIONS

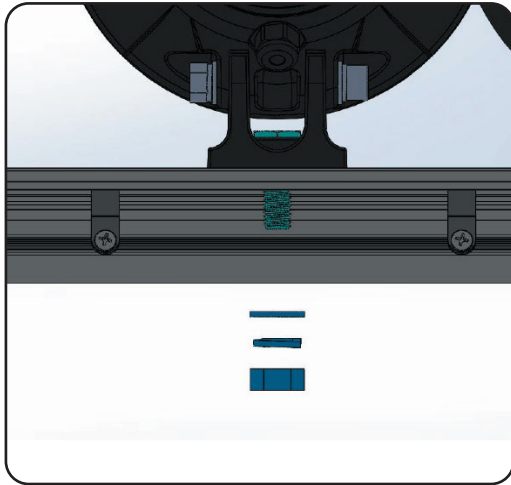

### 1. Mount the Lights

Before installing the X-Bar on your vehicle use the correct size wrench to remove the lights base mounting hardware. Leave the mounting bolt in place. Install the lights onto the bar at the desired mounting locations. Tighten the base mounting hardware until the spring washer is fully compressed. Then tighten to 10ft\*lbs of torque or as tight as is necessary to prevent movement. If the desired spacing is not available with the pre-defined positions drilling will be necessary. There is a small v-groove on the underside, of the bar to center the drill bit on the mounting surface

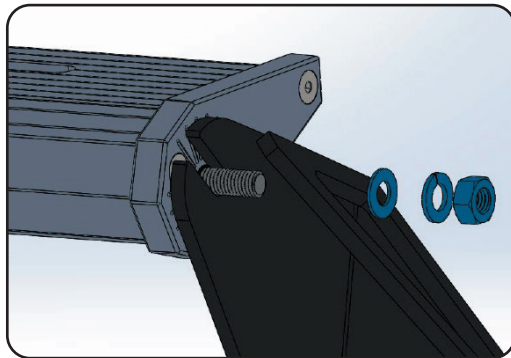

### 2. Install the Xross Bar

Remove the end mounting hardware. Leave the mounting bolt in place. The rubber retainer o-ring will keep the bolt from falling through the end cap. Install the light bar onto your pre-installed 50" light bar mounting brackets. When installing the light bar brackets refer to the bracket's specific instructions, as installation will vary from vehicle to vehicle.

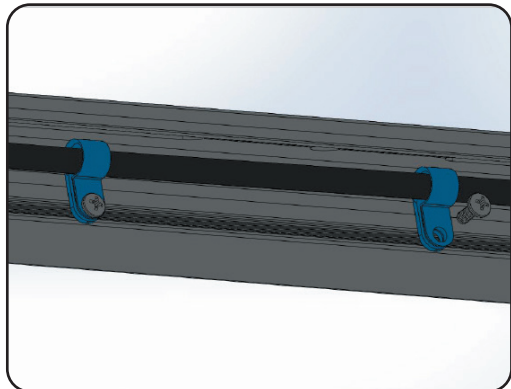

### 3. Wire Management.

The Xross Bar comes with pre-installed wire management. 10 "R-clips" are supplied, that can be used to securely hold and organize the light wiring. To utilize the R-clips, remove the Phillips head screw installed in the horizontal thread channel. Open the R-clip and place the wire through the round section. Thread and tighten the Phillips head screw back into the horizontal thread channel. Repeat this process for all of the wires/ R-clips.

### 4. Wire Harness installation

The KC 50" overhead Xross Bar SlimLite LED 6 light kit comes with turn key wiring for running 3 different switches. For the installation of 3 different switch harnesses see the instructions for part number KC6315, (instructions part #KC3264QB). It is possible to wire all 6 of the lights to one switch with some modification. The following page will walk you through how to wire all 6 lights onto one switch.

**\*\*Note: Making any modifications to the wire harness will void the warranty**

# XROSS BAR 6-LIGHT SLIMLITE LED OVERHEAD SYSTEM INSTALLATION

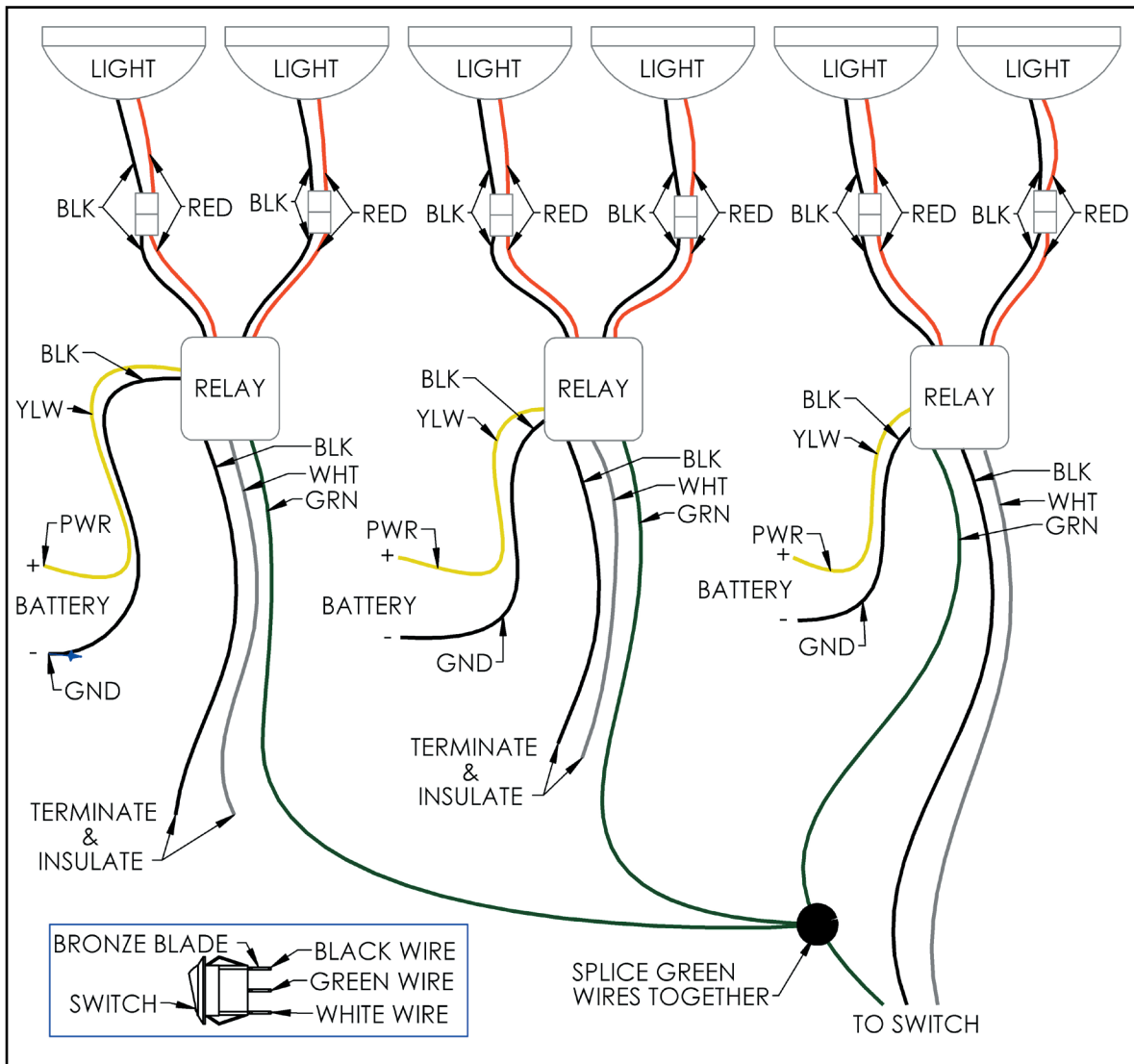

Wiring diagram shows how to install the 6 lights

## 5. Wire Harness Modification (Optional)

When modifying the wire harness to have one switch for 6 different lights it is necessary to splice the green wires together. To do this trim and strip two out of three of the green wires and splice them into the remaining unspliced wire. The easiest way to do this will be to use a 4 wire splice connector. On the remaining harnesses (with the trimmed green wires) terminate and insulate the wires. The easiest way to do this is to wrap electrical tape around the female spade connectors. This will protect the wires from shorting.

## PRODUCT REGISTRATION

Thank you for becoming part of the KC family and purchasing one of our premium KC products! With over 50 years of history in the auxiliary lighting market, you have become a part of our ever growing family. We encourage you to register your product online at [HTTP://REGISTER.KCHILITES.COM](http://register.kchilites.com) to ensure you get all the benefits of owning a KC HiLiTES product.